

USB 2.0 Compliance Testing with Agilent Infiniium

Application Note 1400

Table of Contents

Introduction	1
Basic Specifications	2
Full/Low-Speed Test Suite	3
Full/Low-Speed Test Fixture	4
Signal Quality Test	5
In-Rush Current Check	7
Droop and Drop Testing	8
Back-Drive Voltage Test	8
Hi-Speed Electrical Test Suite	9
Hi-Speed Electrical Test Tool	10
Hi-Speed Test Fixture	10
Hi-Speed Signal Quality Test	11
Monotonicity	11
Packet Parameters Test	12
Receiver Sensitivity	12
CHIRP Timing Test	13
Impedance Measurements	14
Summary	15
Support, Services, and Assistance ...	16

Who Should Read This Application Note?

Digital designers and developers working towards USB 2.0 compliance.

Introduction

Universal Serial Bus (USB) burst on the scene in 1995 delivering a revolutionary way to connect personal computers and devices. Allowing hot-plug capability, USB has introduced ease-of-use to the PC device market by providing a simple connection scheme and protocol for a wide variety of computer devices, ranging from keyboards and mice to high-bandwidth devices such as printers, scanners, and PC cameras.

USB has now successfully replaced aging serial and parallel ports as the connection of choice for both device manufacturers and end users. Whereas cable length and device expansion were limitations with older serial and parallel connections, they are no

issue for USB. Amazingly, it allows devices to exist up to 30 meters away from the host, and allows up to 127 devices to be connected to a single host and port at once through a series of USB hubs. The ability to talk directly to devices or to devices through hubs allows for this incredible expansion capability.

USB 1.1 worked best for slower human-interface devices such as mice and keyboards, with low-speed operating at 1.5 Mb/s and full-speed operating at 12 Mb/s. Higher-bandwidth devices were severely limited by these relatively slow data transfer rates. As a result, the USB-Implementers Forum (USB-IF) introduced the fully backward compatible USB 2.0 in May 2000, which resulted in a 40-fold increase in data throughput for hi-speed over full-speed. USB 2.0 operates at 480 Mb/s—ideal for devices such as video-conferencing cameras and high-resolution printers. For more information, see the official USB website at www.usb.org.



Basic Specifications

As listed previously, USB 2.0 comprises three different data transfer rates—low-speed, full-speed, and hi-speed.

Four wires compose the cable system— V_{BUS} , D+, D-, and ground. Devices may be either bus-powered, with 500 mA maximum bus current withdraw, or self-powered, meaning they have their own power supply. D- and D+ is a differential signal pair that serves as the primary information carrier between the host, hubs, and devices. USB 2.0 supports three different types of data transfer: interrupt, bulk, or isochronous. Control packets containing commands or query parameters may also be sent by the host.

The flexibility inherent in USB is a direct result of the specifications above and the stringent regulations and compliance testing mandated by the USB-IF. There are three kinds of

	Data Rates	Rise Times
Low-speed (LS)	1.5 Mb/s	75 ns – 300 ns
Full-speed (FS)	12 Mb/s	4 ns – 20 ns
Hi-speed (HS)	480 Mb/s	500 ps

Table 1. USB 2.0 speed specifications.

compliance tests: framework test, interoperability test, and electrical test. This document only discusses Infiniium’s electrical test solution.

Low, full, and hi-speed USB require compliance with the signal quality, in-rush current check, droop/drop and back drive voltage electrical tests. Hi-speed requires compliance with an additional suite of electrical tests—hi-speed signal quality, receiver sensitivity, CHIRP timing, and packet

parameters. Older methods of compliance testing included first capturing the signals on a scope, then moving the data to a PC so it could be cropped, stored in a .tsv format, and finally analyzed in MATLAB®. The Agilent Infiniium USB Test Option is the first scope solution in the industry that utilizes the official USB-IF MATLAB script. As the result, it provides an affordable, trustworthy, single-box, compliance solution—allowing you to say, as did one of our customers, “I know I’m going to pass!”

USB Test	Test Type	Report Output
Signal integrity	FSFE, LSFE, LSNE, HSFE, HSNE	Overall result, Signal eye, EOP width measurement, Signaling rate measurement Crossover voltage measurement, Jitter measurement, Signal data diagram, Eye diagram
Inrush Current	Hot Plug, Agilent Config, Agilent Resume, LP Config, LP Resume	Overall result, Inrush current measurement, Inrush current graph
Drop/Droop	System, Self Powered Hub, Bus Powered Hub	Overall Result, Voltage no load measurement, Voltage loaded measurement Drop measurement, Droop measurement

Table 2. Tests included with Agilent USB test option E2645A, N2854A, N2855A, and E2683A.

Full/Low-Speed Test Suite

Agilent test equipment has been approved by the USB-IF. Table 3 shows the equipment required to perform the Full/Low-speed Electrical Test.



Figure 1. Agilent Infiniium at Plugfest.

Low/Full Speed Recommended Equipment (Using Agilent 54815A, 25A, 31B/D, 32B/D, 35A, 45A/B, 46A/B, 52A, 53A, 54A, 55A Scopes)

Part #	Description	Quantity
E2645A [1] N2854A N2855A E2683A	USB 2.0 test option. Includes one SQiDD test fixture for low/full speed USB 2.0 testing for 54815A, 54825A, 54835A, 54845A, 54846A for 54845B, 54846B for 54830B/D Series with software rev. A.02.30 or below for 54830B/D Series, 54833A and 54850A Series with software A.03.10 or higher	1
E2646A	Additional SQiDD (Signal Quality Inrush, Drop/Droop) test fixture for low/full speed USB 2.0 testing (Note that one E2646A is included in the USB test option)	–
54832B/32D Option 004	Adds (four) 1165A passive probes for new purchase of 54832B/32D scopes only	1
54846B Option 004	Adds (four) 1161A passive probes for new purchase of 54846B scopes only	1
E2697A	High-impedance adapter with one 10073C passive probe for 54852A/53A/54A/55A only	3
1147A	50 MHz current probe (for 54831B/D, 32B/D, 45B, 46B only)	1
N2774A & N2775A	50 MHz current probe and power supply (for 54852A/53A/54A/55A)	1
HUB	Intel Customer HUB (CHUB)	5
Adjacent Device	Intel Deluxe PC Camera (for full-speed), USB mouse (for low-speed)	1
Multimeter	34401A	1
USB Host System	Hardware Configuration: 815EEA2 motherboard, Pentium III 700 MHz, 256 MB ram, 40 GB HD, CD (CD-RW), FD, IOGear (or ATEN) USB 2.0 PCI card (5-port) Software Configuration: Windows 2000 or Windows XP	1
USB Cable	5 meter cable 1 meter cable	6 1
USB-IF Tool on Host System [2]	USBCheck or USBCV program from USB-IF, Inc.	1

[1] To use the E2645A option, you must have the following minimum Infiniium configuration: 300 MHz CPU, 64 MB RAM, Windows 98, Version A.04.20 or greater of the system software, LS-120 120 MB SuperDisk. To determine if your Infiniium meets these configuration criteria, look at the back of your unit. If the serial number of your unit starts with US3919 or higher, you meet these requirements. Or if there is a product tag with "E2633A," "E2633-68703," or "E2633-68701," you meet the requirements. If you do not meet the minimum requirements, you must order an Infiniium oscilloscope performance upgrade in addition to the E2645A. Please contact your Agilent representative for selecting the right performance upgrade for your Infiniium oscilloscope.

[2] USB Check is supported on Windows 2000 only and is being made obsolete by USBCV. When performing USBCV to test full/low device, USB 2.0 hi-speed HUB is also needed.

Table 3. Recommended test equipment.

Full/Low-Speed Test Fixture

The basic USB 2.0 electrical test suite includes signal quality, in-rush current check, and droop/drop tests. A SQiDD (Signal Quality inrush Droop Drop) fixture must be used for these tests. Agilent provides a

SQiDD board that can be ordered as option B30 with the purchase of a new Infiniium or separately as part number E2646A. The USB-IF exclusively uses the Agilent SQiDD board for official compliance testing.

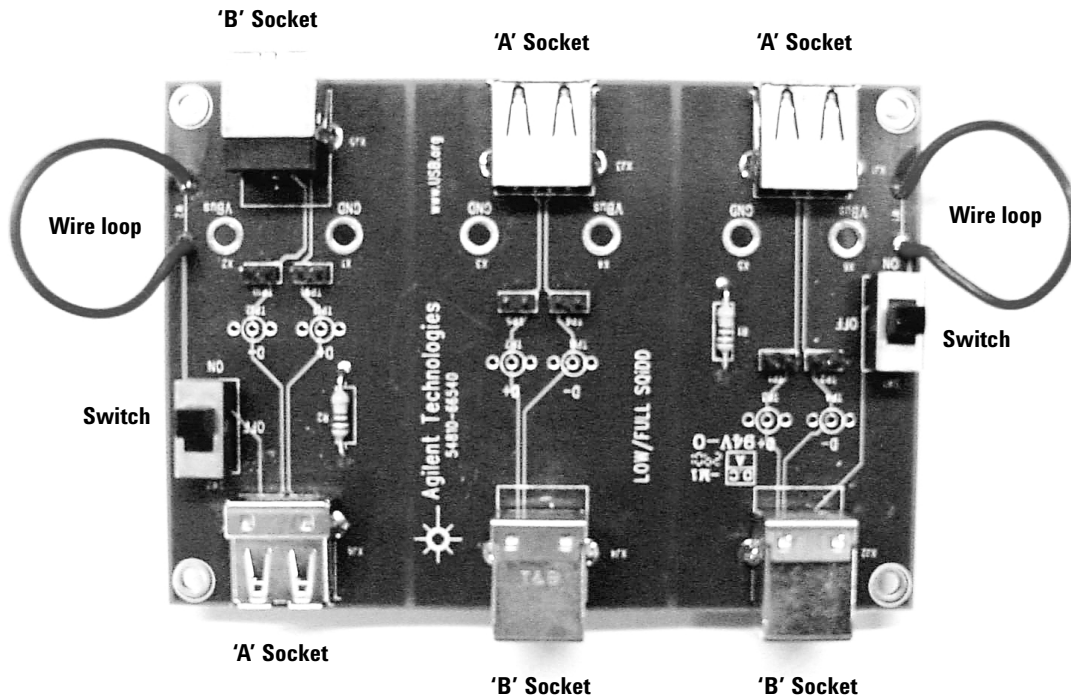

Figure 2. Agilent SQiDD board.

Signal Quality Test

Using an oscilloscope to measure transceiver characteristics, the signal quality test looks at:

- Signal eye
- End of Packet (EOP) width
- Signaling Rate
- Rise/Fall Times
- Cross-over Voltage Range
- Consecutive Jitter
- Paired JK Jitter
- Paired KJ Jitter

Signal quality testing can be performed for either upstream data or downstream data. In the case of upstream testing, signals travelling from the device to the host are captured and analyzed. Downstream testing performs just the opposite, capturing signals travelling from the host towards the device or terminating hub. Figure 3 shows a captured downstream packet on the Infiniium with the USB Test Option.

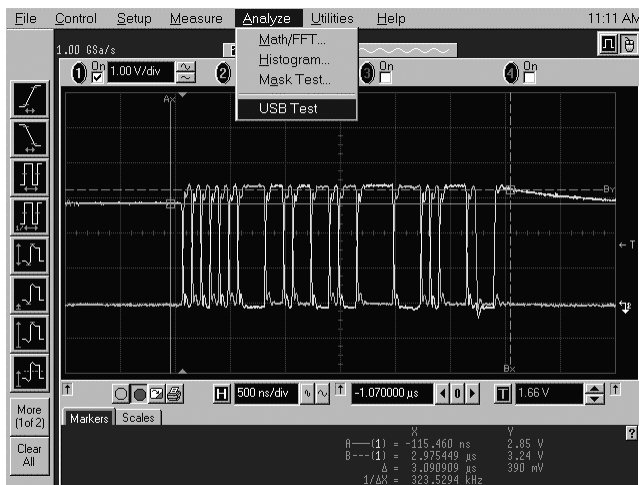

Figure 3. Captured downstream packet.

Signal Quality Test (continued)

Once the USB test is launched, other conditions must also be set in the software. For signal quality tests, these additional conditions include tier and near end/far end. The tier refers to the distance between the device and the host computer. If the device is connected directly to the host computer, the tier equals 1. If the device is separated from the host computer by 3 hubs, the tier equals 4. Compliance testing mandates that testing occur at a minimum tier of 6; therefore, Agilent recommends that tests always be performed with a tier of 6. Test results may be stored in a data file on the Infiniium's C: drive, or may also be stored to a floppy disk.

Infiniium displays all test results in an html format, including the eye diagram.

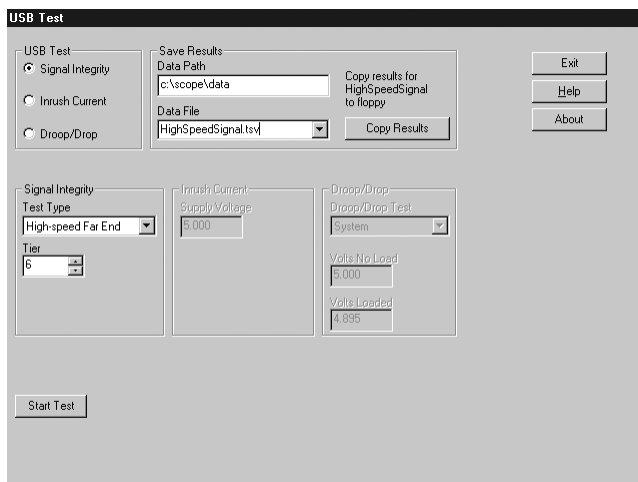

Figure 4. Infiniium USB test menu.

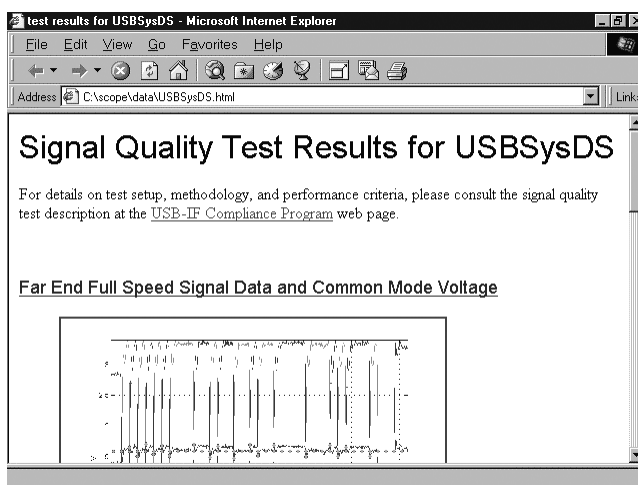

Figure 5. Infiniium signal quality test results.



Figure 6. Infiniium-generated eye diagram for USB test.

In-Rush Current Check

The nature of electronic devices dictates that a surge of current will occur, followed by a lesser steady-state current level, when power is applied to a device. The hot-pluggable nature of USB requires that the transient peak current level be tested to ensure that it remains within the limits for the device. If the current does not remain within its limits, not only can it cause damage to the device, but it can also take power from other devices connected to the same port.

The USB 2.0 specification outlines a current limit of 500 mA.

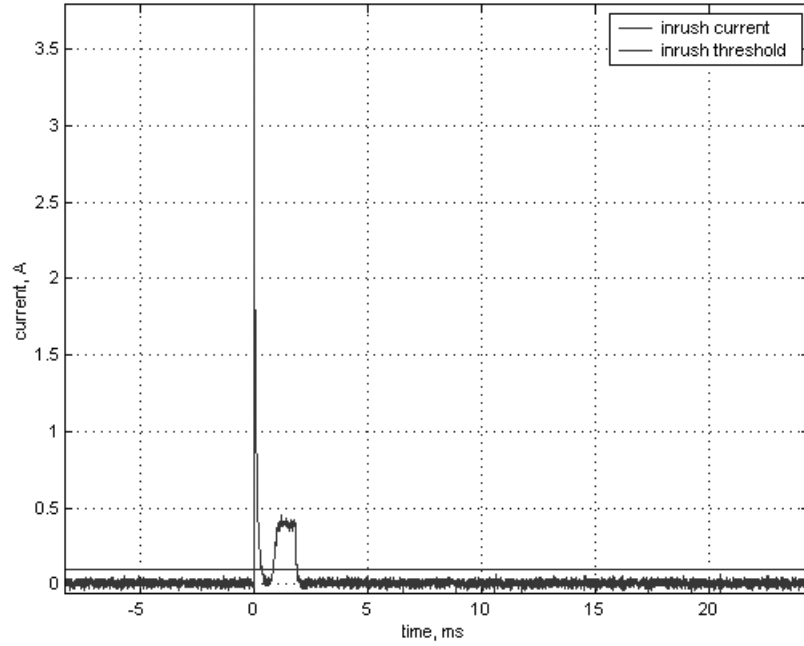

Figure 7. In-rush current spike.

Droop and Drop Testing

Droop and drop testing procedures vary based on whether the device is self-powered or bus powered.

Hosts and Self-Powered Hubs

Drop testing measures the voltage drop across each load board attached to the SQiDD board. To get a good indication of voltage drop, the test is performed under two conditions—no load and load. Under no load testing, all downstream ports remain open, while the V_{BUS} voltage test points on the SQiDD board are probed. Load testing tests the V_{BUS} voltage test points with 500 mA loads applied to all downstream ports. The lowest measured loaded value should be used for the droop test.

Droop testing involves calculating Droop, the voltage on V_{BUS} that occurs when all but one port are under 500 mA loads. The unloaded port is then connected to the SQiDD board. Once the data is captured on the display, markers are used to bracket the area between the lowest point and steady-state voltage point of V_{BUS} . Infiniium then uses the bracketed data to perform the droop test.

Bus-Powered Hubs

Drop tests for bus-powered hubs use 100 mA load boards instead of the 500 mA load boards used in the self-powered hub procedure. These 100 mA boards are connected to all downstream ports. The V_{BUS} voltage is then measured at the hub upstream port and at each downstream port. The lowest measured downstream value is used for the droop test.

The droop test for bus-powered hubs again uses the 100 mA-load board. This load board is connected to all but one port on the bus-powered device. The SQiDD board is then attached to the unloaded port. Once again, markers are used to bracket the area between the lowest point on the captured data and the steady-state voltage. The Infiniium then uses the drop test results and the bracketed data to run the droop test.

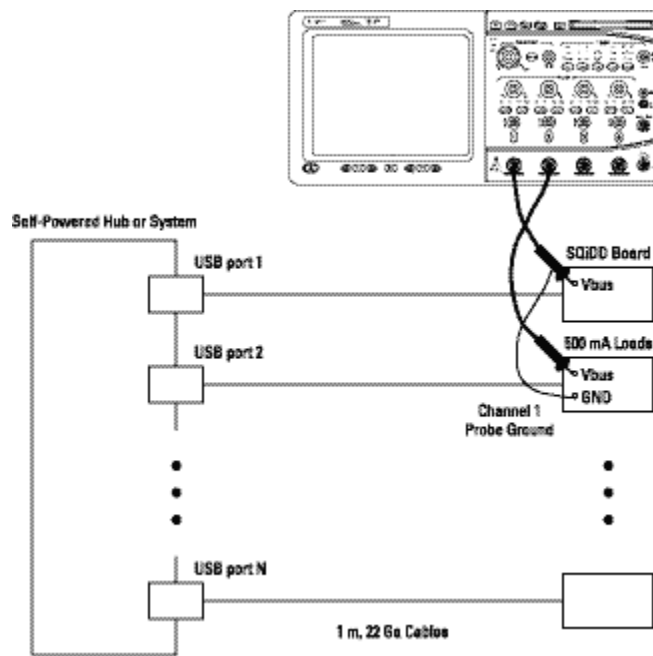

Figure 8. Droop setup for hosts and self-powered hubs.

Back-Drive Voltage Test

The back-drive voltage test is performed to ensure that a device only draws current from V_{BUS} on its upstream facing port at all times. If a device supplies current at this port, a number of consequences can occur, including hub enumeration failure, PC boot failure, and

motherboard failure. This test measures the DC voltages of V_{BUS} , $D+$, and $D-$ before and after device enumeration. The voltages are then recorded on the back-drive voltage fixture. Any voltage exceeding 400 mV is considered a failure.

Hi-Speed Electrical Test Suite

An additional suite of tests was added to the USB 2.0 compliance procedure to accommodate the new hi-speed mode. These tests

include hi-speed signal quality, receiver sensitivity, CHIRP timing, and packet parameter.

The following test equipment is required to perform the hi-speed electrical test.

Hi-Speed Recommended Equipment (Using Agilent 54846A/B, 52A/53A, 54A, 55A)

Part #	Description	Quantity
E2645A [1] N2854A E2683A	USB 2.0 test option. Includes one SQiDD test fixture for low/full speed USB 2.0 testing for 54846A for 54846B for 54852A/53A/54A/55A	1
E2646A	Additional SQiDD (Signal Quality Inrush, Drop/Droop) test fixture for low/full speed USB 2.0 testing (Note that one E2646A is included in the USB test option)	–
E2649A	Hi-speed USB 2.0 test fixture set consists of: E2645-66501 Device Signal Quality test fixture E2645-66502 Host Signal Quality test fixture E2645-66503 Receiver Sensitivity test fixture E2645-66504 Device TDR test fixture E2645-66505 Host TDR test fixture E2645-66506 Host Disconnect test fixture 0950-2546 Power supply	1
54846B Option 004	Adds (four) 1161A passive probes to the 54846B oscilloscope	1
E2697A	High-impedance adapter with one 10073C passive probe for 54852A/53A/54A/55A only (1156A can be used in lieu of E2697A)	3
1130A/31A/32A/34A	InfiniiMax probe amplifier (qty 2 required for hub testing)	1
E2669A	Differential connectivity kit for InfiniiMax probes, or	1
E2678A	Differential socketed probe head	1
01131-68703	Additional set of 10 damped adapters for use with InfiniiMax probes (Note that four damped adapters are included with the E2649A and the E2699A)	–
Digital Signal Generator [2]	81130A Pulse/Pattern Generator 1 MB SRAM Memory Card (#UFH) 81132A 660 MHz option 8493C #006 6 dB attenuator male SMA cable	1 1 2 2 2
TDR [3]	86100A/B 54745A male SMA cable	1 1 2
Multimeter	34401A	1
Hi-Speed USB Test Bed Computer	Hardware configuration: 815EEA2 motherboard, Pentium III 700 MHz, 256 MB ram, 40 GB HD, CD (CD-RW), FD, IOGear (or ATEN) USB 2.0 PCI card (5-port) Software configuration: Windows 2000 or Windows XP	1
USB Cable	1.5 meter cable 1 meter cable	1 1
USB-IF Tool on Host System	USB Hi-speed Electrical Test Tool from USB-IF, Inc.	1

[1] To use the E2645A option, you must have the following minimum Infiniium configuration: 300 MHz CPU, 64 MB RAM, Windows 98, Version A.04.20 or greater of the system software, LS-120 120 MB SuperDisk. To determine if your Infiniium meets these configuration criteria, look at the back of your unit. If the serial number of your unit starts with US3919 or higher, you meet these requirements. Or if there is a product tag with "E2633A," "E2633-68703," or "E2633-68701," you meet the requirements. If you do not meet the minimum requirements, you must order an Infiniium oscilloscope performance upgrade in addition to the E2645A. Please contact your Agilent representative for selecting the right performance upgrade for your Infiniium oscilloscope.

[2] Digital Signal Generator is required when testing receiver sensitivity test for device/hub.

[3] TDR test was deleted from Hi-speed Test Procedure (Rev. 1.0), but it is still recommended to test when at development stage.

Table 4. Recommended test equipment.

Hi-Speed Electrical Test Tool

On the hi-speed USB Test Bed Computer, the USB hi-speed Electrical Test Tool is required.

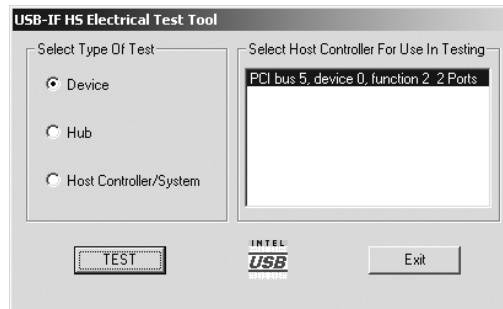

Figure 9. USB-IF hi-speed electrical test tool.

Hi-Speed Test Fixture

The hi-speed signal quality test utilizes the hi-speed signal quality board, as shown in Figure 10.

The nomenclatures of the test points differ between the Agilent hi-speed test fixture and the Intel test fixture. The official USB test procedure is written with reference to Agilent’s test fixtures. Refer to Table 5, the cross-reference chart, when using Intel’s test fixture.

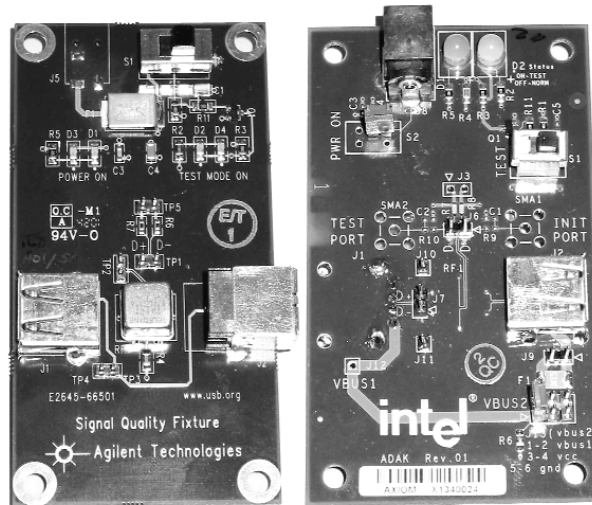

Figure 10. Hi-speed signal quality boards (Agilent fixture and Intel fixture—device signal quality test).

Intel’s Fixtures	Description of the test points	Agilent Fixtures
J7	Test Point	TP2
J8	Power Port	J5
J10	Ground	TP5
J11	Ground	TP5
SMA1	D- line	SMA2
SMA2	D+ line	SMA1

Table 5. Cross-reference chart.

Hi-Speed Signal Quality Test

Invoke the Hi-speed Electrical Test Tool software on Electrical Test bed Computer and select TEST_PACKET to perform the signal quality test. Figure 11 shows a hi-speed test packet captured on Infiniium.

Prior to testing, it must be determined if the device incorporates a captive cable, or if it contains a series B or mini-B connector. During upstream tests, captive cables require that tests be run at the far end. B-connector cables require that tests be run at the near end. Figure 12 shows a hi-speed eye pattern result displayed on Infiniium.

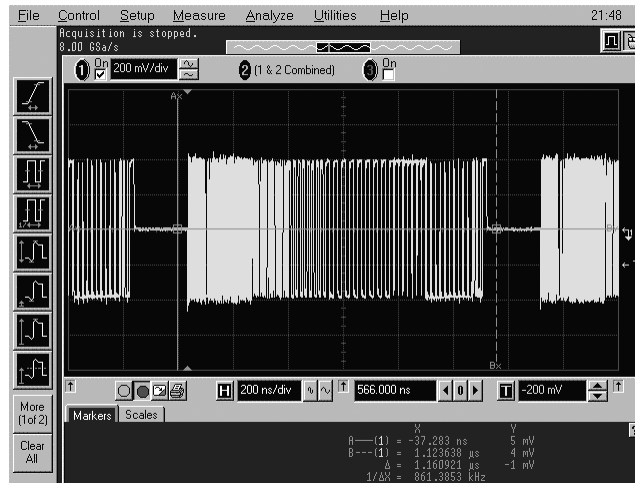

Figure 11. Hi-speed test packet.

Monotonicity

Monotonicity tests if a transmitted signal increases or decreases in amplitude without reversal in the opposite direction. The monotonicity characteristic of a signal is determined using the hi-speed signal quality eye template (Figure 12). There is no independent monotonicity test mandated by the USB-IF.

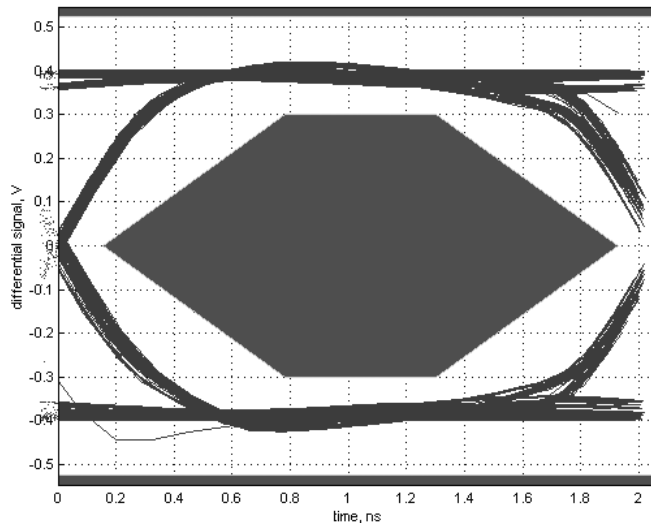

Figure 12. Hi-speed signal quality eye diagram.

Packet Parameters Test

Another test using the hi-speed signal quality board tests the device packet parameters. The hi-speed signal quality test board allows for better reception of the packets coming from the device. This test measures parameters such as sync field length, end of packet (EOP) width, and inter-packet gap.



Figure 13. Device inter-packet gap.

Receiver Sensitivity

The receiver sensitivity tests verify sensitivity of the receivers of a device on both the upstream and downstream data ports in noisy environments. The Agilent 81130A Pulse/Pattern Generator is used to emulate IN commands from the port to the device address 1. IN commands are sent from the computer to the device under test, which should be in an unsequelched mode. The noise is represented by a pre-set level, whereby a signal meeting and exceeding this level responds to the IN command with an NAK. All packets from the data generator must be NAK'd by the port under test. The amplitude of the data generator packets is then reduced in 20 mV increments as the test is run. The amplitude of these packets should be reduced until the NAK packets become infrequent. The data generator amplitude is then immediately increased to the point where the

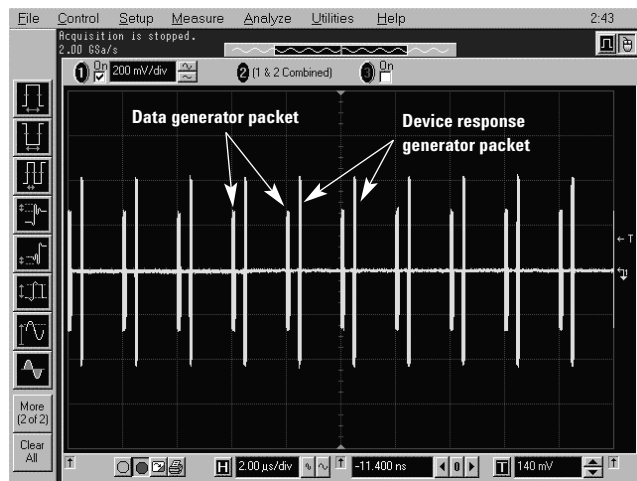

Figure 14. Receiver sensitivity test.

NAK packets are not intermittent. This indicates the points of minimum receiver sensitivity levels before squelch.

When the device receives IN packets with a signal amplitude in excess of 150 mV, all packets

should be NAK'd. When the device receives IN packets with a signal amplitude below 100 mV, all packets should be squelched. A waiver is granted for squelch at +/- 50 mV for each level.

CHIRP Timing Test

The CHIRP test utilizes the hi-speed signal quality test fixture to measure timing and voltage on both upstream and downstream ports. The device is hot-plugged to the port and is immediately enumerated to capture the CHIRP handshake. Within the handshake, the CHIRP-K duration is measured to verify that it is within the 1.0 ms and 7.0 ms allowable latency. After the CHIRP K-J, K-J, K-J sequence, the device responds by turning on its hi-speed terminations. A drop of amplitude from 800 mV nominal to 400 mV nominal occurs. The time between the beginning of the last J in the CHIRP K-J, K-J, K-J sequence and the time when the device turn on initiates its hi-speed terminations must be measured to verify that it is less than or equal to 500 μ s.

In addition to measuring the time between the last J in CHIRP and the initiation of hi-speed termination, the CHIRP test also measures device suspend/resume/reset timing as well as the K and J amplitudes.

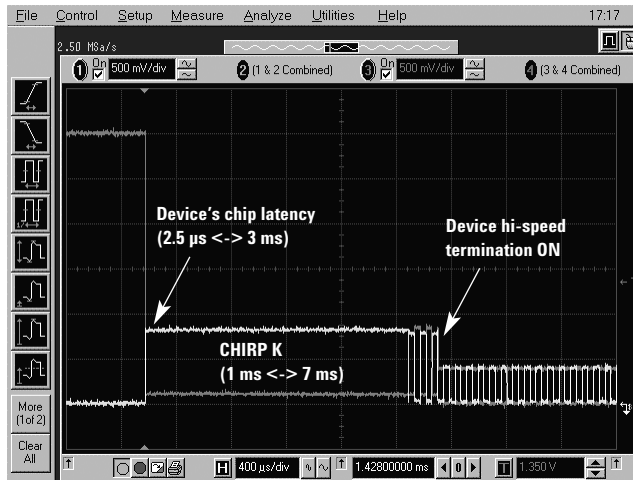

Figure 15. CHIRP test.

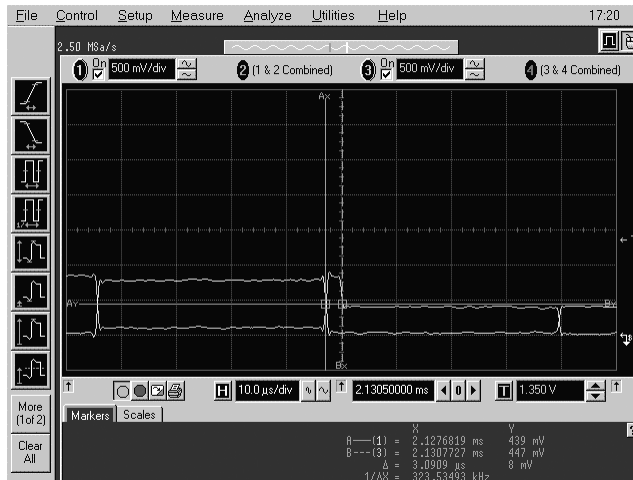

Figure 16. Time between last J in CHIRP and hi-speed termination initiation.

Impedance Measurements

In this test, differential time domain reflectometer (TDR) measurements are taken to measure the impedance of the hi-speed signaling path and active terminations of the device under test. The TDR measurements are compared with the USB-IF specification requirements. The device under test is powered, placed in SE0-NAK mode, and isolated from the system. D+ and D- are measured to verify that they are $0\text{ V} \pm 10\text{ mV}$. A 400 ps edge is then driven into the device. The resulting waveform indicates whether or not the termination impedance and the through impedance meet the requirements. The TDR measurement is not required for compliance testing. A PASS signal quality test will suffice for the TDR measurement.

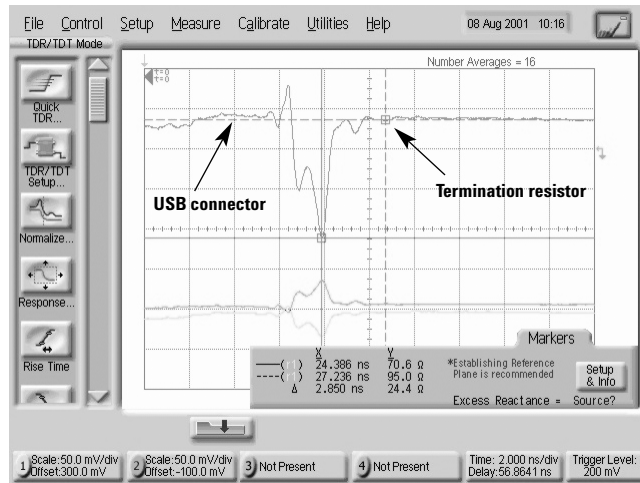

Figure 17. TDR measurement.

Summary

Agilent provides a comprehensive, easy-to-use solution for USB compliance testing. The compliance testing that once took days now takes 5 minutes. The individualized test boards provide flexibility and affordability for the laboratory choosing to test facets of the USB specification simultaneously.

In conclusion, the Agilent Infiniium USB Test Option has been described this way: *“The term ‘God Send’ comes to mind. Before the arrival of this scope, a USB test was something to be avoided! It often required half a day to set up the test and an additional 30 minutes to massage the numbers into an acceptable MATLAB format.*

Needless to say only the minimum number of tests required was ever actually performed.

“In a nutshell, this product has revolutionized the way in which we look at USB. We now have a designated test system that is reliable and easy to use and fast. The main result is that we can now provide real-time feedback, and the amount of testing we perform is probably up 30-fold or more. And as you may have guessed, the additional testing has turned up a myriad of interesting opportunities for future improvements. Just for fun we have even started looking at our competitor’s products!”

Infiniium Oscilloscope	Operating System	Software Revision	USB Test Option	Tests
5481xA, 5482xA	Windows® 98	A.04.20 or higher	E2645A	Low/Full Speed
5483xB/D	Windows 98	A.01.10 or higher	N2855A	Low/Full Speed
5483xB/D	Windows XP Pro	A.03.10 or higher	E2683A	Low/Full Speed
54845A	Windows 98	A.04.50 or higher	E2645A	Low/Full Speed
54846A	Windows 98	A.04.50 or higher	E2645A	Low/Full/Hi Speed
54845B	Windows 98	A.04.50 or higher	N2854A	Low/Full Speed
54846B	Windows 98	A.04.50 or higher	N2854A	Low/Full/Hi Speed
5485xA	Windows XP Pro	A.03.10 or higher	E2683A	Low/Full/Hi Speed

Table 6. Infiniium USB Test Option

Additional Resources

USB 2.0 Test Tool available at URL://www.usb.org/developers/tools.html.

1. USBCV
2. USBCheck
3. USB Hi-Speed Electrical Test Tool Kit

Official USB 2.0 Test Procedures may be obtained at URL: //www.usb.org/developers/docs.html

1. Host/Hub/Device Hi-Speed Electrical Test Procedures for Agilent Infiniium 54853A, 54854A, 54855A Revision 1.2, August 6, 2003
2. Host/Hub/Device Hi-Speed Electrical Test Procedures for Agilent Infiniium 54846B and 1131A Revision 1.1, August 23, 2003
3. Hi-Speed Electrical Test Procedures for Agilent Test Equipment Revision 1.0, February 5, 2002

Agilent Technologies' Test and Measurement Support, Services, and Assistance

Agilent Technologies aims to maximize the value you receive, while minimizing your risk and problems. We strive to ensure that you get the test and measurement capabilities you paid for and obtain the support you need. Our extensive support resources and services can help you choose the right Agilent products for your applications and apply them successfully. Every instrument and system we sell has a global warranty. Support is available for at least five years beyond the production life of the product. Two concepts underlie Agilent's overall support policy: "Our Promise" and "Your Advantage."

Our Promise

Our Promise means your Agilent test and measurement equipment will meet its advertised performance and functionality. When you are choosing new equipment, we will help you with product information, including realistic performance specifications and practical recommendations from experienced test engineers. When you use Agilent equipment, we can verify that it works properly, help with product operation, and provide basic measurement assistance for the use of specified capabilities, at no extra cost upon request. Many self-help tools are available.

Your Advantage

Your Advantage means that Agilent offers a wide range of additional expert test and measurement services, which you can purchase according to your unique technical and business needs. Solve problems efficiently and gain a competitive edge by contracting with us for calibration, extra-cost upgrades, out-of-warranty repairs, and on-site education and training, as well as design, system integration, project management, and other professional engineering services. Experienced Agilent engineers and technicians worldwide can help you maximize your productivity, optimize the return on investment of your Agilent instruments and systems, and obtain dependable measurement accuracy for the life of those products.



Agilent Email Updates

www.agilent.com/find/emailupdates

Get the latest information on the products and applications you select.



Agilent Direct

www.agilent.com/find/agilentdirect

Quickly choose and use your test equipment solutions with confidence.

Agilent T&M Software and Connectivity

Agilent's Test and Measurement software and connectivity products, solutions and developer network allows you to take time out of connecting your instruments to your computer with tools based on PC standards, so you can focus on your tasks, not on your connections. Visit www.agilent.com/find/connectivity for more information.

By internet, phone, or fax, get assistance with all your test & measurement needs

Online assistance:

www.agilent.com/find/assist

Phone or Fax

United States:

(tel) 800 829 4444

Canada:

(tel) 877 894 4414

(fax) 800 746 4866

China:

(tel) 800 810 0189

(fax) 800 820 2816

Europe:

(tel) (31 20) 547 2323

(fax) (31 20) 547 2390

Japan:

(tel) (81) 426 56 7832

(fax) (81) 426 56 7840

Korea:

(tel) (82 2) 2004 5004

(fax) (82 2) 2004 5115

Latin America:

(tel) (305) 269 7500

(fax) (305) 269 7599

Taiwan:

(tel) 0800 047 866

(fax) 0800 286 331

Other Asia Pacific Countries:

(tel) (65) 6375 8100

(fax) (65) 6836 0252

Email: tm_asia@agilent.com

Product specifications and descriptions in this document subject to change without notice.

© Agilent Technologies, Inc. 2004

Printed in USA

August 31, 2004

5988-6219EN

